

Itemref	Quantity	Type	Order/Job No
		THERMOTECH TPS IGU	

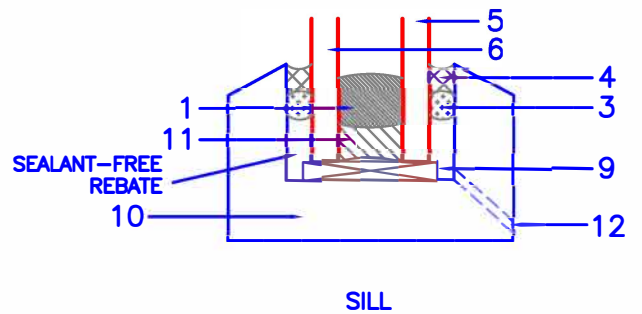

### TYPICAL FRAME DETAILS

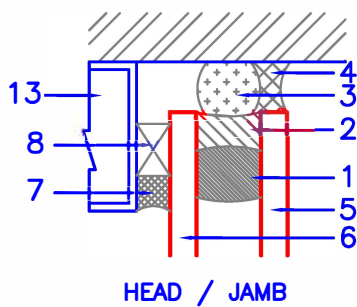
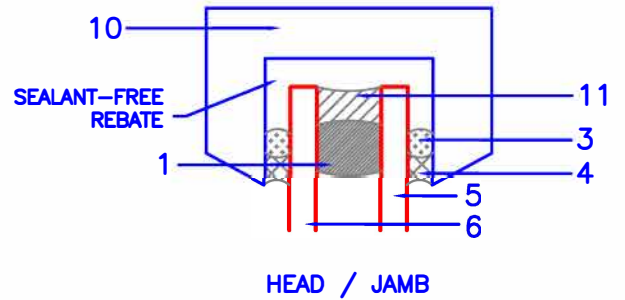
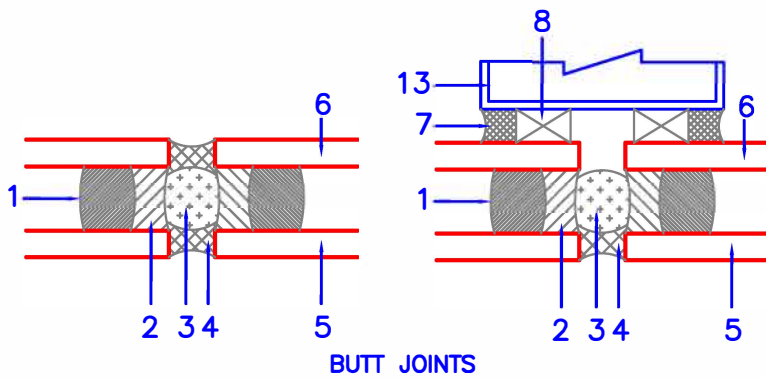
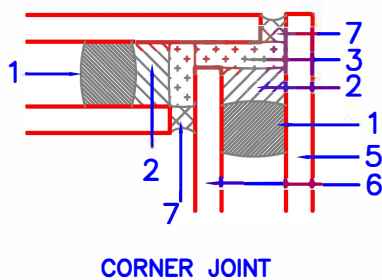
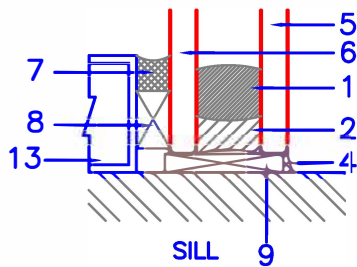

### TYPICAL STRUCTURAL GLAZING DETAILS

#### CODE EXPLANATION:

- 1 BLACK TPS SPACER
- 2 SECONDARY SEAL (DOW CORNING 982)
- 3 BACKER ROD (CLOSED-CELL PE RECOMMENDED)
- 4 WEATHER SEAL (DC991 & DC995 RECOMMENDED)
- 5 OUTER PANE
- 6 INNER PANE
- 7 STRUCTURAL SEALANT (DC995 RECOMMENDED)
- 8 SPACER BLOCK
- 9 SETTING BLOCK (PE OR PP RECOMMENDED)
- 10 WINDOW FRAME
- 11 SECONDARY SEAL (GD116-POLYSULPHIDE)
- 12 WEEP HOLE
- 13 SUPPORT FRAMING

#### NOTES:

- 1 THIS DRAWING SHALL BE READ IN CONJUNCTION WITH THERMOTECH TPS IGU TECHNICAL SPECIFICATION FOR GLAZING.
- 2 IN GENERAL, SEALANTS ARE NOT TO BE USED TO SECURE GLAZING BLOCKS IN SEALANT-FREE REBATE.
- 3 ALL MATERIALS USED FOR GLAZING MUST BE CHECKED FOR COMPATIBILITY WITH THE COMPONENTS OF IGU.
- 4 INCOMPATIBLE SEALANTS AND GLAZING BLOCKS WILL VOID THE WARRANTY.

Designed by TL	Checked by	Approved by – date	Filename Glazing details_a	Date 2/09/2008	Scale N.T.S.
-------------------	------------	--------------------	-------------------------------	-------------------	-----------------



Title/Project TYPICAL GLAZING DETAILS FOR THERMOTECH TPS IGU		
Drawing number VIR-IGU-001	Rev. A	Sheet